

**120**mm sq.

# San Ace 120WF

38mm thick (9WF type)



## General Specifications

- Material ..... Frame: Plastics (Flammability: UL94V-0),  
Impeller: Plastics (Flammability: UL94V-0)
- Expected Life ..... Refer to specifications (L10:Survival rate: 90% at 60°C ,  
rated voltage, and continuously run in a free air state)
- Lead Wire ..... ⊕red ⊖black (Sensor) yellow
- Storage Temperature ..... -30°C to +70°C (Non-condensing)

The product can be used in an oil mist environment\*

\*Environment where machining oil mist is scattered.  
Usage of this product requires an evaluation with the oil that will be used.

**120×120×38mm** (Mass : 355g) **9WF type**

## Specifications

The following nos. **have pulse sensors and ribs.**

Model No.	Rated Voltage [V]	Operating Voltage Range [V]	Rated Current [A]	Rated Input [W]	Rated Speed [min <sup>-1</sup> ]	Max. Airflow [m <sup>3</sup> /min] [CFM]	Max. Static Pressure [Pa] [inchH <sub>2</sub> O]	SPL [dB(A)]	Operating Temperature [°C]	Expected Life [h]
<b>9WF1224H101</b>	24	20.4 to 27.6	0.32	7.68	3,100	3.34 118	100 0.40	46	- 20 to + 70	40,000

Some models can also be equipped without sensors as an option. Please refer to the index (pp. 417 to 437).

## Dimensions (unit : mm)

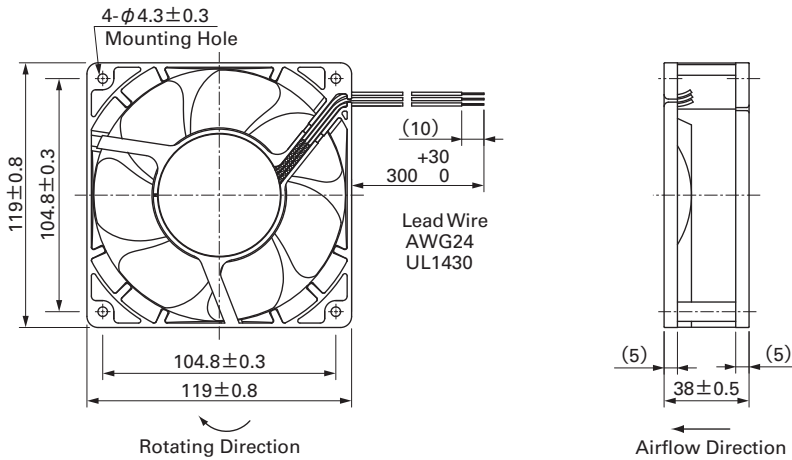

## Reference Dimension of Mounting Holes and Vent Opening (unit : mm)

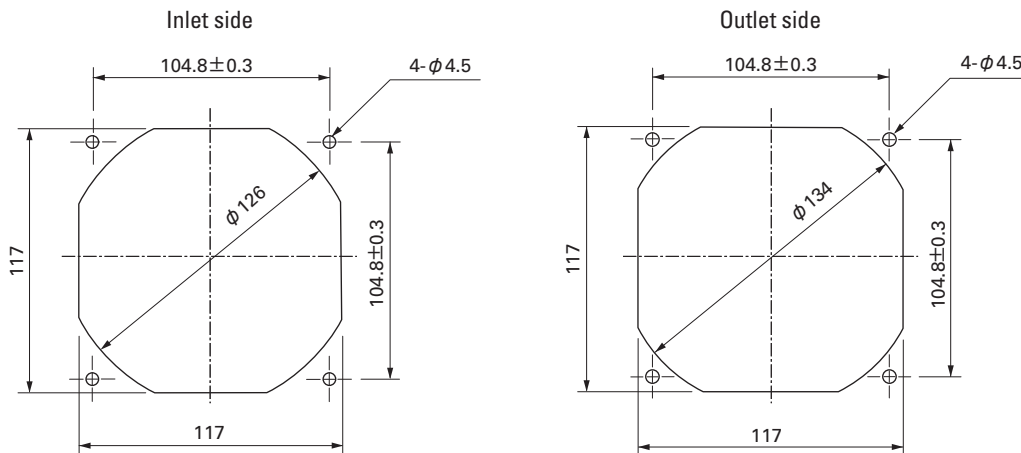

## Options (unit : mm)

### Finger Guards

Model : 109-019C Surface treatment : Nickel-chrome plating (silver) Color : 109-019H Cation electropainting (black)

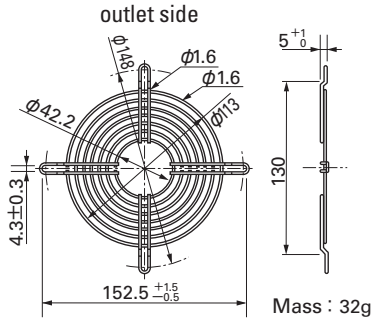

Model : 109-019E Surface treatment : Nickel-chrome plating (silver) Color : 109-019K Cation electropainting (black)

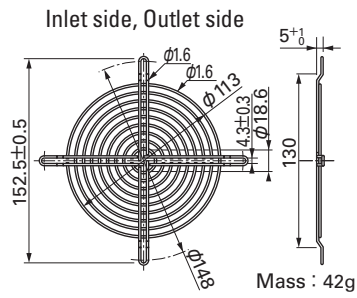

## Airflow - Static Pressure Characteristics

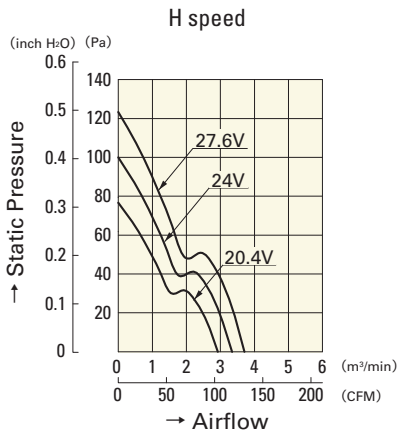

**9WF1224H101**